

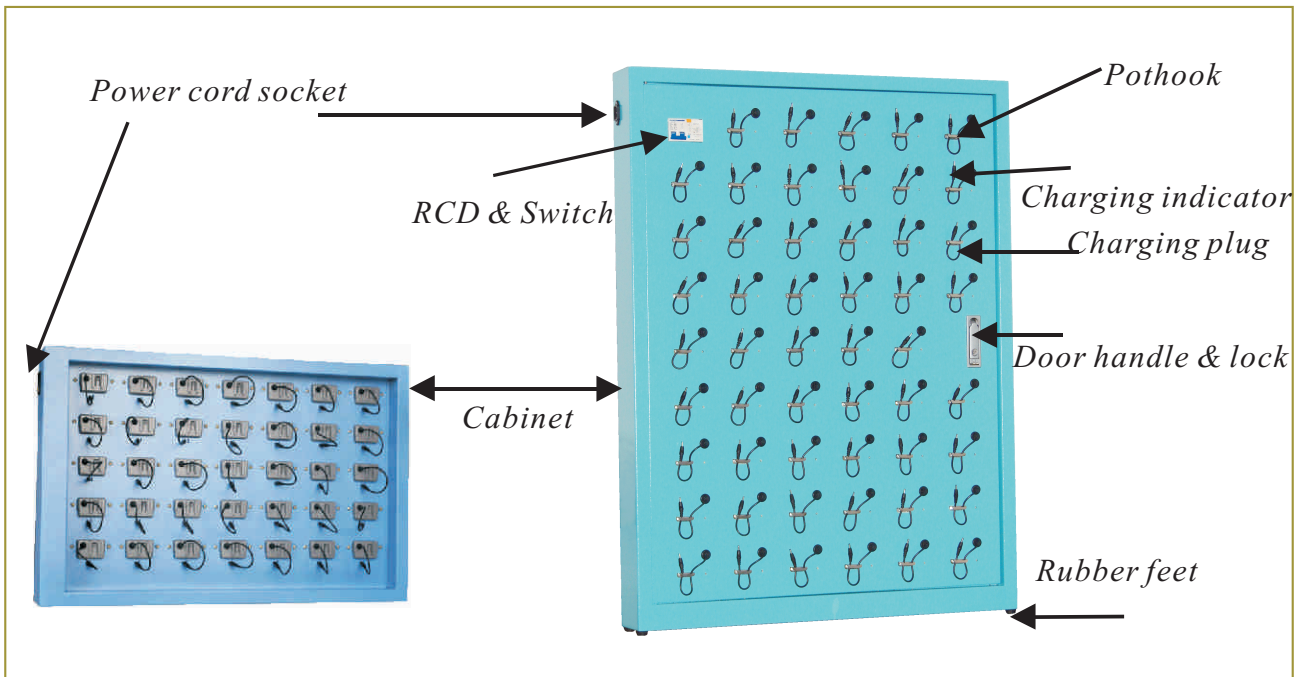

A Charging Bank charges multiple lamps together. All our Cordless Caplamps and Helmet Lamps are compatible for all charging banks, except external models. Charging banks are compact, light weight, high capacity, low current and easy to use. The automatic over-load protection function in each charging unit will cut off the charging circuit when the lamp is fully charged and therefore you never need to intervene in the charging process once you start it. CB52 charging unit has an indicator for charging process. The lamp can be locked to the Charging Bank. Cb52 and CB35 have individual low-power charging circuit board for each charging unit. A built-in power supply generates 12VDC power for charging units. For CB52, a panel mount RCD sits between the 240VAD mains power input and the power supply for personal protection. This low power distribution to charging units makes it very safe and suitable for mining applications. Front panel can be opened and locked for convenient service.

### STRUCTURE

#### External



#### Internal

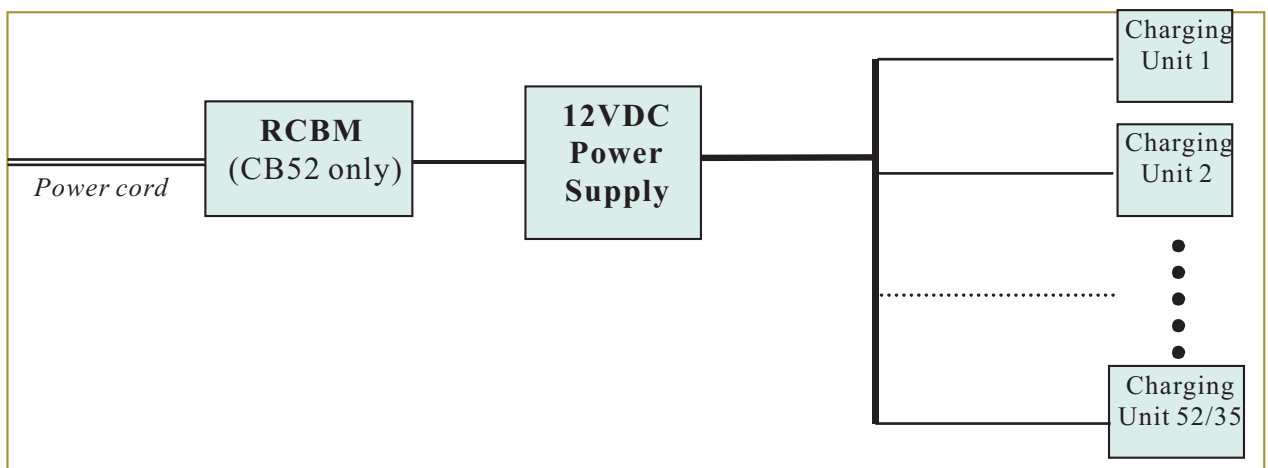



### LOCK

Padlocks can be supplied as optional accessories for CB52. The padlock locks the clip of a caplamp to the pothook. It is suggested to use our lock. Your own lock may not match lamp clip slot, pothook and this compact space.



### INSTALLATION

CB52 and CB35 are wall mounting equipment. Four mounting holes locate on four corners on the back panel. Open the door and you can access these mounting holes. CB52 also can just stand on a bench against wall. Four rubber feet are supplied to fix underneath the cabinet.

### CHARGING PROCEDURE

There are two Charging Indicators as follows:

LCI (Lamp Charging Indicator): LCI is in the lamp. It only indicates whether the charging power is connected or not. It is always in red.

CCI (Charger Charging Indicator): CCI is on the charging bank or on the charger. It indicates the charging stages in two colours, by detecting the charging current. Green - No or small charging current; Red - Large charging current.

- Find a charging unit without lamp. The corresponding CCI should be 'on' in green;
- Turn off the lamp;
- Plug the charging cable into the charging socket of the lamp and hook the lamp on the unit;
- The LCI should turn on; Otherwise, check the connection;
- The CCI should turn red, indicating the initial charging stage if the lamp battery level is low;
- After a few hours, the CCI will turn the colour in red and green alternatively, indicating the late charging stage;
- When the CCI stays in 'green', the charging process is completed and the lamp is fully charged.

### SPECIFICATIONS

| Model              | CB35            | CB52        |
|--------------------|-----------------|-------------|
| Input:             | AC 195_264V     |             |
| Output:            | DC 5.1V / 500mA |             |
| Power Consumption: | < 175W          | < 250W      |
| Dimension:         | 87x11x56cm      | 114x84x11cm |
| Weight:            | 16kg            | 31kg        |

